



Connections Between Bullying and Other Types of Violence: Family Violence, Sexual Harassment, and Dating Violence

March 26th, 2015

Meeting Orientation Slide



- Ø If you are having any technical problems with the webinar please contact the Adobe Connect hotline at 1-800-416-7640 or type it into the Q&A box.
- Ø For audio, listen through computer speakers or call into the phone line at 866-835-7973.
- Ø Type any additional questions or comments into the Q&A box on the left.

Presenter



Dorothy Espelage, Ph.D.

Department of Educational Psychology
University of Illinois, Urbana-Champaign

Connections among Family Violence & Bullying, Sexual Harassment Perpetration Across Adolescence

Dorothy L. Espelage, Ph.D.

Professor, Educational Psychology

Edward William Gutgsell & Jane Marr Gutgsell Endowed Professor
Hardie Scholar

University of Illinois, Urbana-Champaign

espelage@illinois.edu; dlespelage@gmail.com

www.dorothyespelage.com

Twitter: DrDotEspelage



Funding Sources & Disclaimer

- Waves 1 – 5 research was supported by Centers for Disease Control & Prevention (#1U01/CE001677) to Dorothy Espelage (PI); *Opinions, findings, and conclusions or recommendations expressed in this presentation are those of the author(s) and do not necessarily reflect those of the CDC*
- Waves 6 & 7 research was supported by NIH Grant (MUOFX-0022) to Dorothy Espelage (PI) & Sabina Low (co-PI); *Opinions, findings, and conclusions or recommendations expressed in this presentation are those of the author(s) and do not necessarily reflect those of the Department of Justice*



Poll #1

True or False

Bullying during middle school has been identified as a precursor to sexual harassment & teen dating violence?



Developmental model of bullying, sexual harassment & dating violence

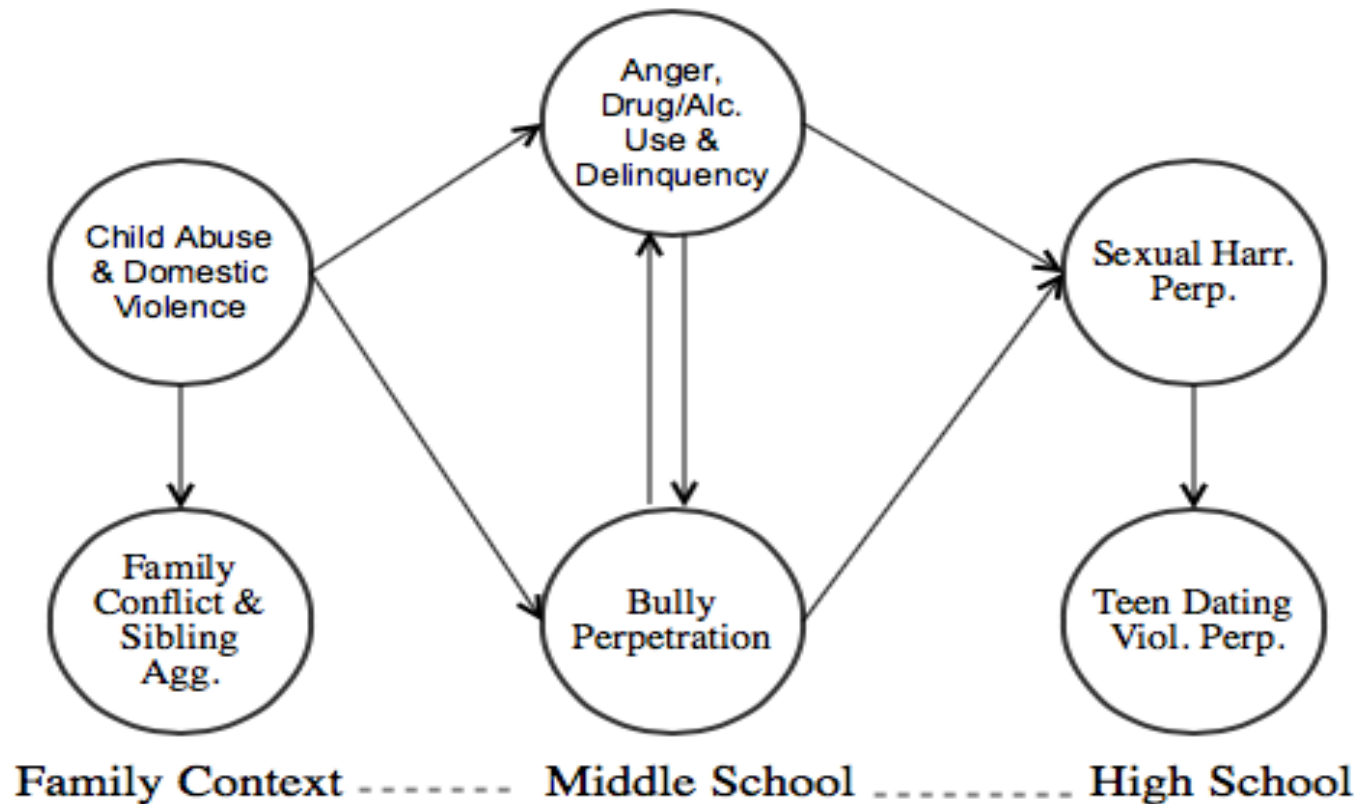

Current Study

- Bullying can be broadly construed as social interactions (or social dynamic) that are influenced, maintained or mitigated by relationships in the school, peer, and familial contexts (Pepler et al., 2006).
- Few studies have investigated family context of bullying perpetration (e.g., Wang, Iannotti, & Nansel, 2009), and the majority of the existing studies on the topic have been cross-sectional.
- Our research is predicated on a social-ecological model and a social interactional learning model in which family violence serves as an important context for understanding the relation between bullying perpetration and involvement in anger and delinquency as predictors of sexual harassment perpetration and teen dating violence.



Family Context & Bullying

- Coercive exchanges between parents and children in the home often co-occur with abusive and conflictual family dynamics, which have been linked to bullying.
- Several cross-sectional (see Espelage, Bosworth & Simon, 2000) and a handful of longitudinal findings (see Voisin & Hong, 2012), direct and indirect exposure to family violence is linked to bullying behavior.
- Strong evidence links family conflict and sibling aggression to bully perpetration, thus, we hypothesized these associations would emerge even in this larger longitudinal path analysis (Espelage, Low, Rao, & Little, 2013).



Bullying/Peer Victimization & Sexual Violence Overlap

- Bullying perpetration associated with sexual harassment perpetration among high school students in Brazil (DeSouza & Ribeiro, 2005).
- Correlations among bullying victimization and sexual harassment victimization (Pepler et al., 2006).
- Bullying perpetration in 6th grade predicted 7th grade sexual harassment perpetration (Pellegrini, 2001).
- Large percentage of bullying among students involves the use of homophobic teasing and slurs, called homophobic teasing or victimization (Espelage et al., 2009; Poteat & Espelage, 2005; Poteat & Rivers, 2010).
- Bullying perpetration predicted sexual harassment perpetration in a 2 ½ year longitudinal study of 5th – 7th graders (Espelage et al., 2012; Espelage et al., 2014)



Violence, Delinquency, & TDV

- Violence against peers has been correlated with using sexual and physical violence against dates (Ozer & Weinstein, 2004).
- Early antisocial behavior (including alcohol and drug use) and aggression have been shown to predict later use of violence against dating partners in three longitudinal studies (Capaldi & Clark, 1998; Lavoie et al., 2002; Simons, Lin, & Gordon, 1998).
- Brendgen, Vitaro, Tremblay, & Lavoie (2001) showed aggression perpetrated by young adolescent boys was associated with dating violence perpetration at the age of 16 and 17 years.



Bullying, SV, & TDV Overlap

- Bully-SV link theory – bullying perpetration predictive of sexual violence over adolescence time and share similar risk factors (Basile et al., 2009; Espelage, Basile et al., 2012, 2014).
- Miller and colleagues (2013) demonstrate how dating violence and bullying often co-occur, highlighting the need to recognize the interrelatedness of these behaviors.



Family Predictors of TDV

- Perceived laxness of parental monitoring and harsh parenting at age 10-12 years and antisocial behavior at age 15 were associated with greater psychological and physical dating violence perpetration at ages 16 and 17 were at-risk of becoming involved in violent dating relationships at age 16 (N = 717 boys; Lavoie et al., 2002).
- These findings were consistent with previous studies highlighted in the Foshee and Matthew (2007) review where parental supervision predicted dating abuse perpetration (Brendgen et al., 2001; Capaldi & Clark, 1998; Foshee et al., 2001).



Mediators – Family & TDV

- Lichter and McCloskey (2004) interviewed 208 mother-child pairs (recruited 1990 and 1991) from violent and nonviolent homes about exposure to marital violence twice over a 7-9 year duration.
 - Results indicated that adolescents exposed to marital violence during childhood were more likely to justify the use of violence in dating relationships than adolescents were not exposed to marital violence.
- More recent studies have also reported an intersection between inter-parental violence and acceptability of dating violence on the prediction of teen dating violence perpetration among adolescents (Temple, Shorey, Tortolero, Wolfe, & Stuart, 2013; Makin-Bryd & Bierman, 2013).



Mediators – Family & TDV

- Other studies of male participants point to the importance in identifying mediators of transmission of relationship conflict and violence across contexts.
 - Most recently, Kim and colleagues (2009) found that emotional dysregulation and poor parenting skills at young ages were key mediators in predicting relationship conflict among 190 men and their mothers and fathers across 21 years.
- Thus, anger is identified as a potential candidate mediator between family conflict/violence and aggression over time.



Rationale for Current Study

- Many comprehensive, social-contextual theories remain untested given the dearth of longitudinal studies focused specifically on teen dating violence (for Review see Shorey, Cornelius, & Bell, 2008).
- Despite overlap and continuity in violence across contexts and lifespan, few studies examined peer linkages between family characteristics and TDV or the potential mediating role of involvement with delinquency and anger.
- Many longitudinal studies are part of larger evaluations of dating violence intervention/efficacy studies – limited etiological data and might limit the types of data collected.



Addressing Research Gaps

Current longitudinal study addresses gaps in the literature by:

- 1) Testing an ecologically-driven model that incorporates the influence of peers, parents and familial factors
- 2) Evaluating the changing influence of key socializing agents across early to late adolescence.
- 3) Examining the antecedents, correlates, and sequela of bullying, sexual harassment, and teen dating violence.



Developmental model of bullying, sexual harassment & dating violence

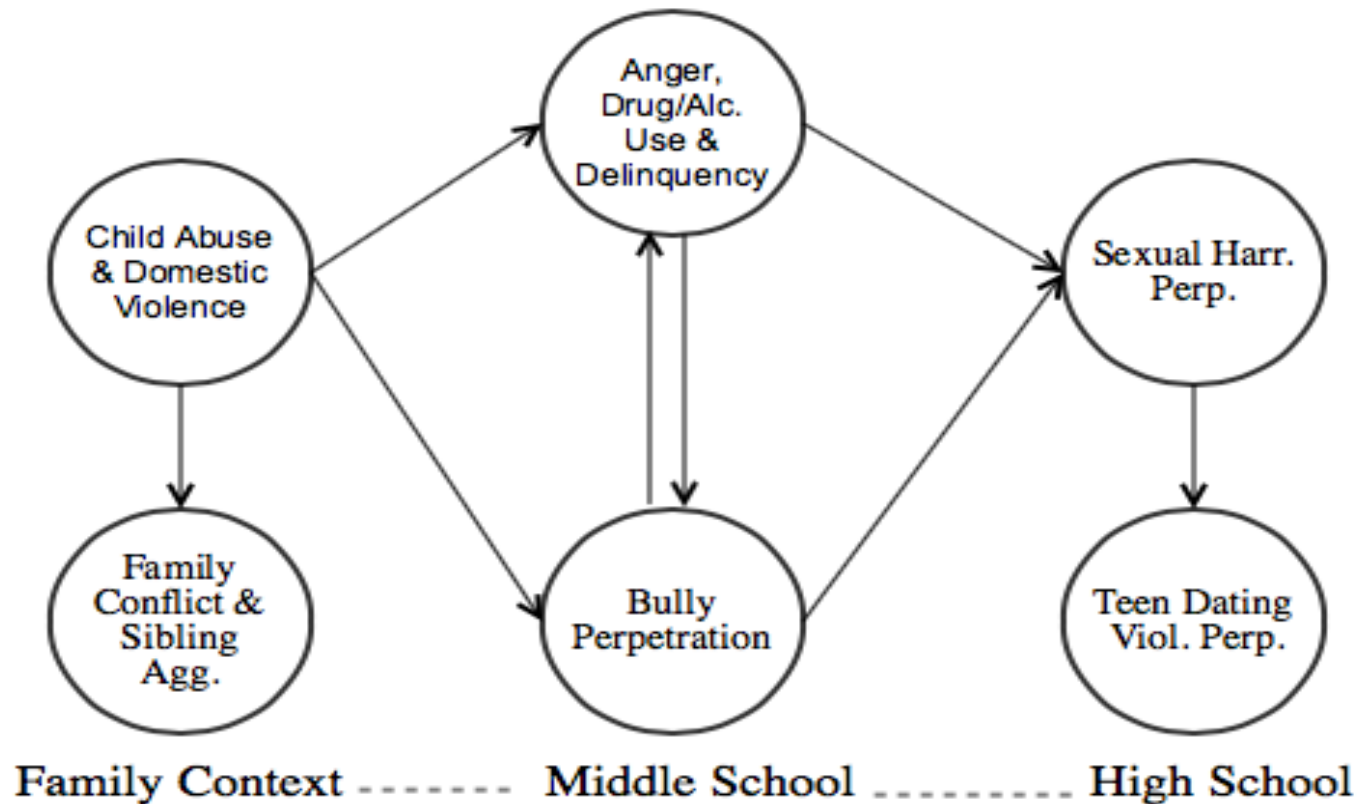

Study Participants

} Demographics:

- 1162 students (49.1% female)
- 3 cohorts (5th, 6th, 7th graders)
- Wave 1 age mean = 11.81 years (SD = 1.09)
- Racially diverse (51% Black, 26% White)
- 60% Free/reduced lunch
- Seven waves of data collection
(spring 2008; fall 2008; spring 2009; fall 2009;
spring 2010; spring 2012, spring 2013)



Measures

Family Factors:

- Family Conflict
- Sibling Aggression
- Physical Abuse
- Sexual Abuse
- Exposure to Domestic Violence



Measures (Continued)

Individual Factors:

- Anger
- Self-reported Delinquency
- Alcohol/Drug Use

Peer Factors:

- Peer Delinquency
- Bullying Perpetration
- Sexual Harassment Perpetration



Teen Dating Violence Perpetration Assessment

- Conflict in Adolescent Dating Relationships Inventory (CADRI; Wolfe et al., 2001)

[By “dating,” we mean spending time with someone you are seeing or going out with. Examples of this might include hanging out at the mall, in the neighborhood, or at home or going somewhere together like the movies, a game, or a party. It doesn’t have to be a formal date or something you planned in advance and it may be with a small group. The term “date” includes both onetime dates and time together as part of long--term relationships.]

If you have started dating (even one date), fill in the bubble that is your best estimate of how often you did the following to anyone you were dating. As a guide, use the following scale:

- **Never:** this has never happened in your relationships
- **Seldom:** this has happened only 1-2 times in your relationships
- **Sometimes:** this has happened about 3-5 times in your relationships
- **Often:** this has happened 6 times or more in your relationships



TDV Frequencies

- Verbal TDV perpetration
 - 31% did something to make partner angry.
 - 26% used hostile tone with partner.
- Relational TDV perpetration
 - 29% kept track of partners activities.
- Physical TDV perpetration
 - 10% slapped or hit partner.
 - 11% bit partner.
- Sexual TDV perpetration
 - 6% forced partner to kiss.



TDV Perpetration – Gender Differences

- Verbal TDV perpetration
 - 68% females and 52% males reported at least one item.
- Relational TDV perpetration
 - 25% females and 21% males reported at least one item.
- Physical TDV perpetration
 - 43% females and 28% males reported at least one item.
- Sexual TDV perpetration
 - 18% females and 23% males reported at least one item.

Scale level differences: η^2 s = .05, .01, .00, .05



Data Analysis Plan

- A series of path analysis were run:
 - Waves 6 and 7 data combined as highly correlated
 - We fit the model to each of the correlation matrices from the 30 complete imputed data sets
 - Results were averaged over the 30 models using Rubin 's (1987) rules
 - Co-variances were estimated for all exogenous variables
- Models were run separately for boys and girls



Fit Indices for the Girls Model

Fit Statistic	Mean	Std.	Min	Max
RMSEA	0.034	0.003	0.031	0.044
Abs. Mean Residual	0.019	0.002	0.017	0.023
Off-diagonal mean residual	0.020	0.002	0.018	0.023



Path Analysis Results (Girls)

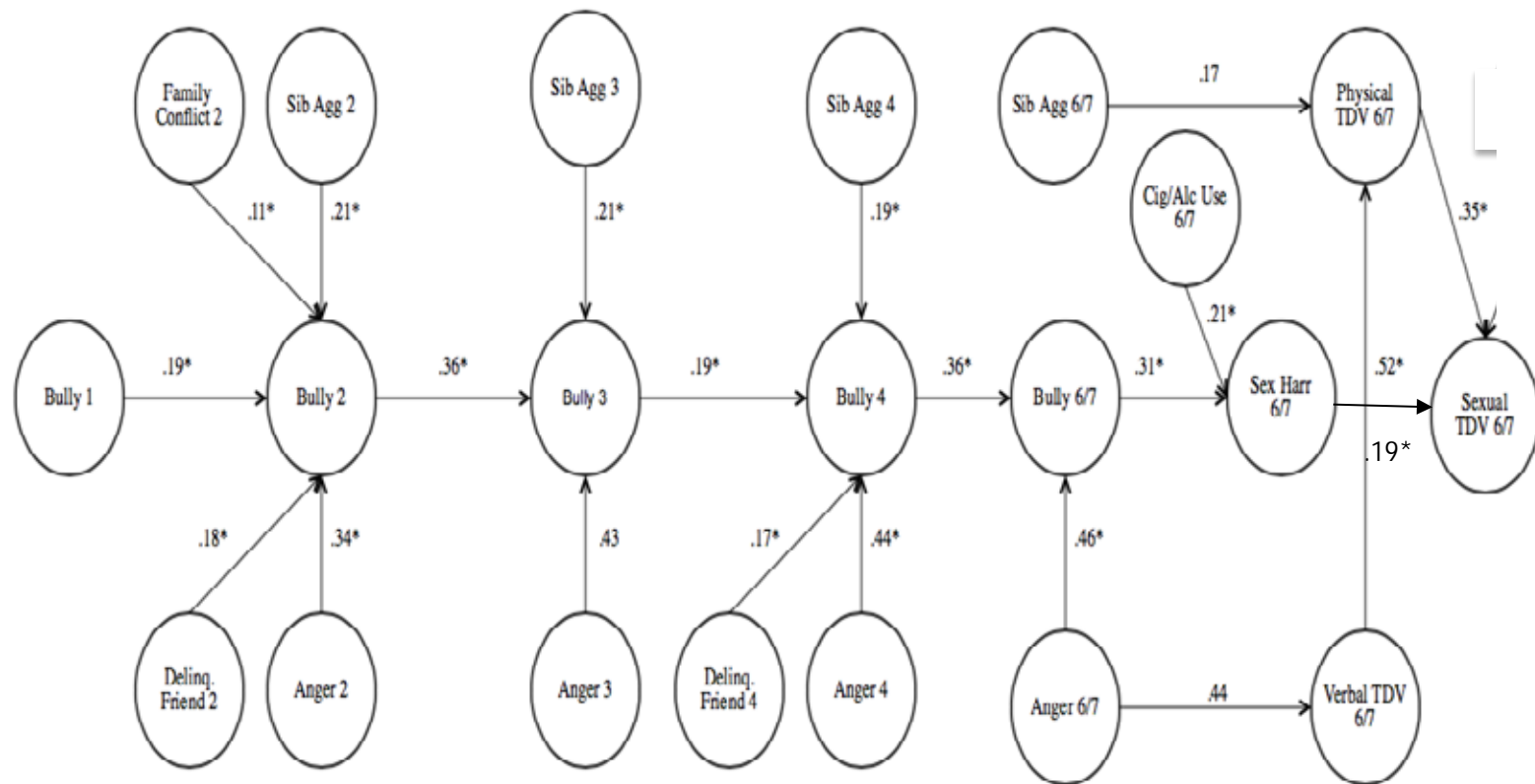

Fit Indices for the Boys Model

Fit Statistic	Mean	Std.	Min	Max
RMSEA	0.035	0.004	0.024	0.045
Abs. Mean Residual	0.020	0.002	0.013	0.025
Off-diagonal mean residual	0.021	0.003	0.013	0.026



Path Analysis Results (Boys)

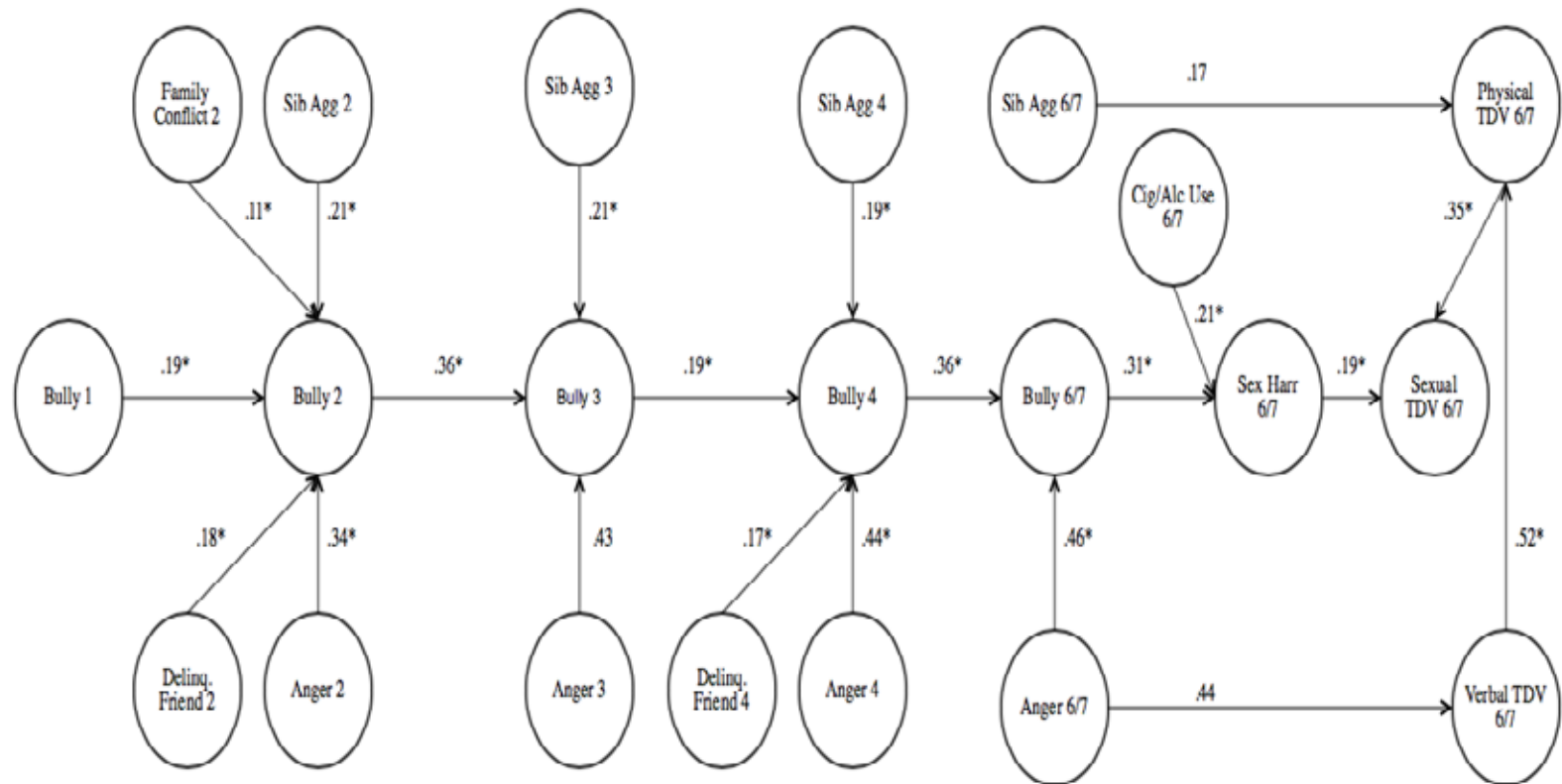

Summary

- Exposure to family trauma and violence dropped out of the models.
- The final models for girls and boys were a good fit to the data.
- For boys and girls, sibling aggression, bullying others, and anger at previous waves significantly predicted bullying behavior across waves 2 through 4.
- For boys, bullying and sibling aggression were predictive of bully perpetration in middle & high school, but family conflict did not predict the associations among bully, sexual harassment, and teen dating violence.
- Further, for all youth, delinquency, alcohol and drug use, and bullying predicted sexual harassment & teen dating violence in high school.



Poll #2

True or False

Teen dating violence prevention programs should start to be implemented in high school and not any earlier?



Implications for Prevention & Intervention

- Bullying programs need to incorporate discussion of gender-based name-calling, sexual violence, and gender expression (homophobic language; Birkett & Espelage, 2010).
- Prevention of bullying & youth violence should address exposure to family violence & include opportunities for youth to address their attitudes supportive of aggression
- Anger management should be incorporated into all violence prevention efforts



Implications for Research

- Research must consider multiple contexts to identify longitudinal predictors, mediators, moderators associated with outcomes for youth who bully.
- Evaluation studies need to assess & address multiple forms of teen dating violence victimization & perpetration
- Increase research attention to sexual coercion in dating relationships – especially for girls



Questions?

Additional Resources

[Building Capacity to Reduce Bullying- IOM](#)

[Workshop Summary](#)

[StopBullying.gov website](#)

[StopBullying.gov Blog](#)

[CSN Bullying Prevention Resource Guide](#)



Save the Date

Bullying Gets Under Your Skin: Effects of Bullying on
Children and Youth

April 27, 2:00-3:00 PM Eastern Time

Registration coming soon



Thank You!

Please complete this brief evaluation
<https://www.surveymonkey.com/r/9YWDDWT>

Contact Information

Children's Safety Network
Education Development Center, Inc.
43 Foundry Ave, Waltham MA 02453
www.ChildrensSafetyNetwork.org
1-617-618-2178

